

SCREEN IN A BOX

QUALITY SCREEN FENCING



Installation Instructions

Index: (A) Punched Frame - (B) Blade - (C) Punched Frame

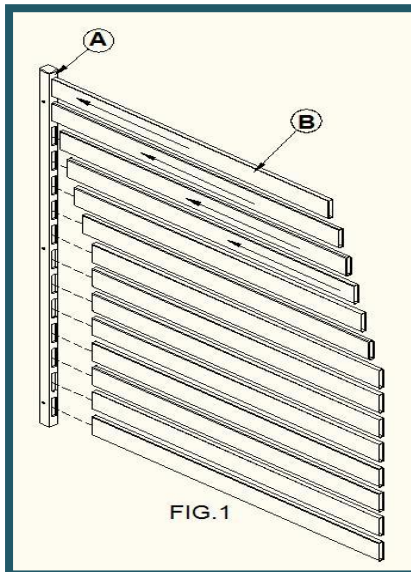

FIG. 1

Step 1 – Place the punched frame (A) on the ground making sure the underneath surface is protected from scratching. Insert blades (B) into punched holes in the punched frame (A)

Step 2 – One at a time, push the blades (B) down, until they engage the lower tension leg of the frame (A). If necessary, tap the ends of the blades with a **Rubber Mallet**, to make sure the blades are in as far as they can go.

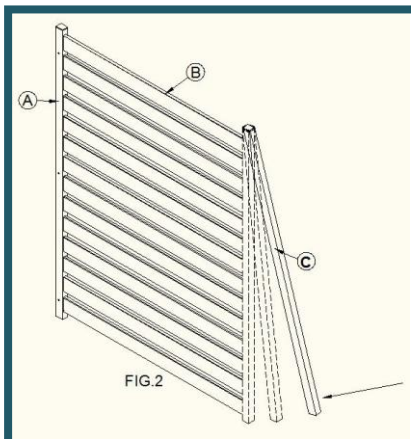
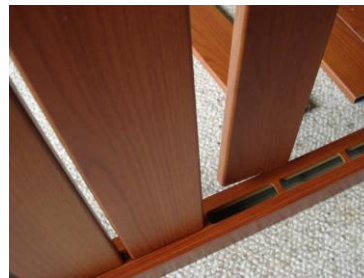

FIG. 2

Step 3 – Starting from the left hand side, feed the blades (B) one at a time into the punched frame (C). Slowly rotate the punched frame (C) and engage the other blades, one at a time until they are all inserted. **See FIG. 2**

Step 4 – When all the blades are engaged, push down hard along the length the frame (C).

Step 5 – Using the rubber mallet, tap the top of the punched frame along its length, until the tension legs are fully engaged around the blades.

HELPFUL HINTS:

USE A SOFT RUBBER MALLETT ONLY

PROTECT THE UNDERSIDE SURFACE FROM SCRATCHING BY USING A SOFT MATERIAL LIKE A PIECE OF CARPET.

USE A PIECE OF WOOD WITH FOAM RUBBER ON THE BOTTOM, TO SIT ON THE FRAME (C) TO AVOID DENTING

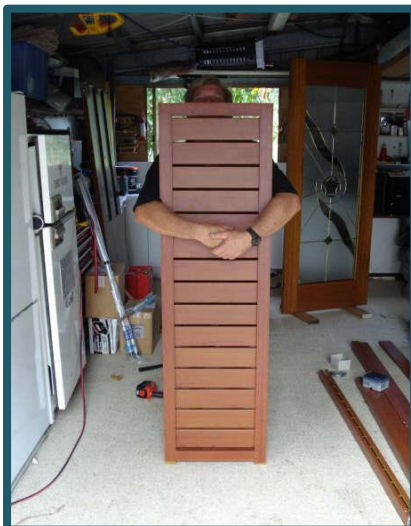

Austech External Building Products

80 Tattersall Road, Blacktown NSW 2148

Ph: 02 9831 1623

Fax: 02 9831 5043

Email: sales@ austech.com.au

www.austech.com.au